

ARTICLE NO. / DESCRIPTION	CAPACITY	TYPE	MODEL	INSTALLATION
37030500 / INV-HPB 500	500L	PRESSURIZED	HEAT PUMP BOILER	FLOOR STANDING

version.4

constructive specifications

capacity	500L
tank material	RVS / stainless steel AISI 444 (EN 1.4521)
thermal insulation	PUR / polyurethane foam 75mm thickness, CFC-Free and HCFC-Free
casing	painted galvanized carbon steel DX51D
temperature gauge	0 - 120°C
coils material and connections	RVS / stainless steel AISI 316L
coil surface area	4,00m ²
coil kW rating output 85/60°C	100kW
max. operating pressure	8bar (0,8MPa)
test pressure	12bar (1,2MPa)
maximum working temperature	90°C
heating element (optional)	immersion connection 1½"
weight (empty / full)	105kg / 591kg
heat losses	82W (EN 12897)
ErP class	B
internal code	68.500.HPI.01.V01B

connections and dimensions

connections

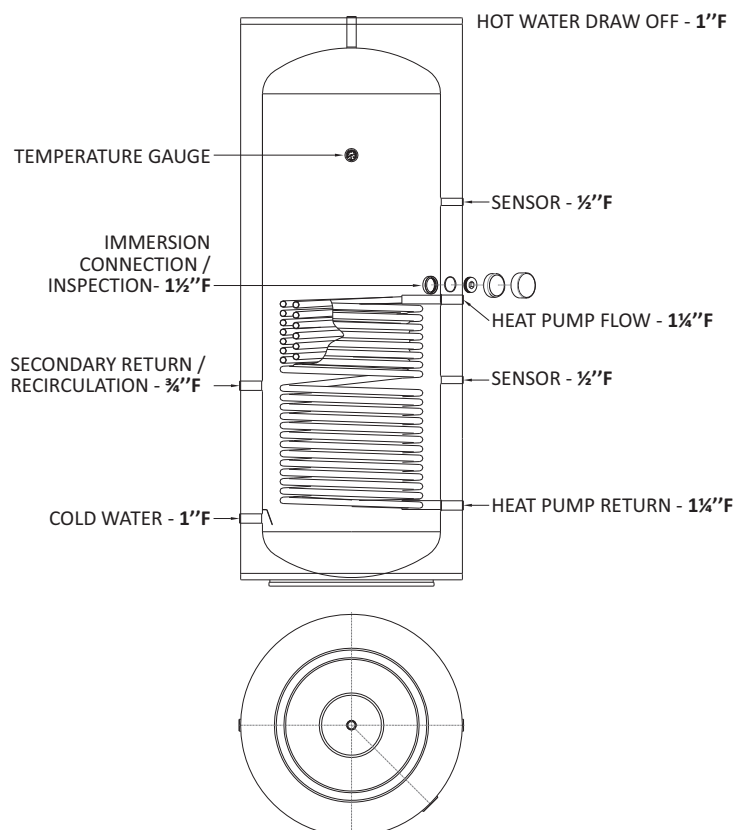

dimensions

